



info@solar-europe.co.za
www.solar-europe.co.za
087 654 4800



Stick Logger (WiFi)

Product Model:
LSW-3



Introduction

By collecting operating data and power generation of inverter, stick logger (WiFi) can run a long-term and efficient monitoring of PV system. Logger can connect to single inverter via RS232 interface, which enables to collect all the data of PV system from the inverter. Meanwhile, remote monitoring cloud platform (SOLARMAN Portal) provides powerful data support for the logger. Logger sends the data to the monitoring platform via WiFi. The real-time status and historical data can be displayed with graphs, enabling intuitive and clear understanding of PV system. Furthermore, customized alerts can notify users of any malfunction or defect immediately via SMS and E-mails, which realizes the management of PV system at anytime and anywhere, also simplifies the maintenance significantly. Stick logger (WiFi) is applicable to the power plant projects in remote areas where no cable laying.

The WiFi module is integrated inside the logger, which enables to transmit data through the WiFi network.

Product Parameter

Catalog	Parameter	Value
Wireless Parameters	Working Frequency	2.412GHz~2.484GHz
	Transmitting Power	802.11b: +14 +/-2dBm(@11Mbps)
		802.11g: +14+/-2dBm(@54Mbps)
		802.11n: +13+/-2dBm(@HT20, MCS7)
Antenna Option	External WiFi Stick Antenna	
Hardware Parameters	Data Interface	RS232
	Working Voltage	DC5V-DC12V
	Max. Working Voltage	DC 15V
	Working Power	1.5W
	Indicator Light	One connected to inverter
		One connected to router
		One heartbeat indicator light
	Data Storage	Default: 2MBYTE FLASH
Working Temperature	-30°C~+70°C	
Working Humidity	Relative humidity: 10%-90%, no condensation	

Hardware Parameters	Storage Temperature	-45°C~+90°C
	Storage Humidity	<40%
	IP Grade	IP65
	External Interface	DB9
Software Parameters	Number of Connections	One
	Serial Communication Rate	Default: 9600bps (1200-115200bps Optional)
	Data Transmission Interval	Default: 5 mins (1-15 mins Optional)
	Configuration	AT+Instruction set
		Local web configuration
		Remote server
	Firmware upgrade	Local web upgrade
		Remote update
	Working Mode	AP+STA
	Others	Real-time Control, Data resuming

Module Interface Identification

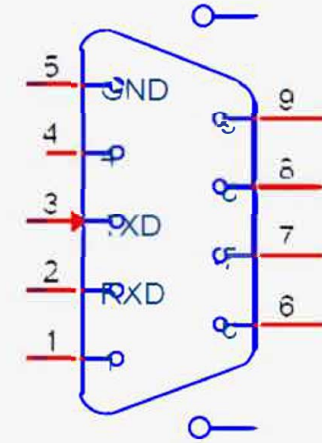

Pin	Description	Network Name	Type	Detail
2	Receiving data	RXD	I	RS232 receiving (RS485_ B line, TTL_RX)
3	Sending data	TXD	O	RS232 sending (RS485_ A line, TTL_TX)
1, 4, 6, 7, 8	Suspended	NC		Not used
5	Power GND	GND	Power	External Power: GND
9	Power VCC	DC_VIN	Power	External Power: DC 5V-12V (at least 3W supply)

Product Pictures



Front View

(DB9"1、2、3、4、5"Pin directing to indicator lights)



Back View



Side View

Logger Size (Unit: mm/Accuracy: $\pm 2\%$)

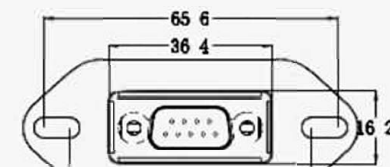
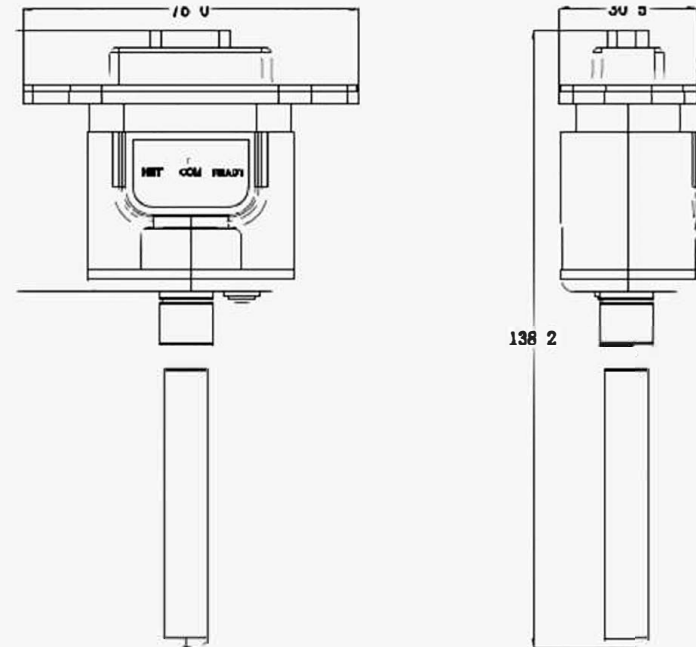

Logger Antenna (Unit: mm)

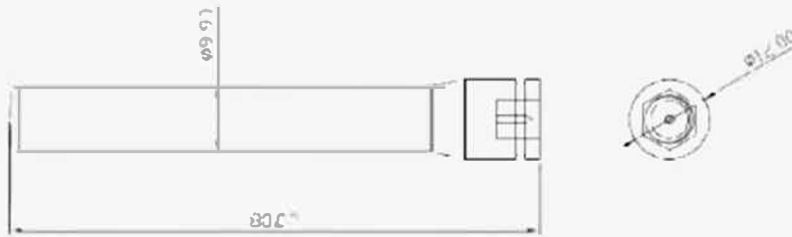

Size of Antenna

Antenna electrical performance index:

Classification	Performance Parameter
Frequency rang-MHz	2.412GHz~2.484GHz
VSWR	≤3.0
Input Impedance-Ω	50Ω
Gain-dBi	3dBi (Max.)
Working Temperature-°C	-30°C~+70°C
Antenna Color	Black
Input connector	SMA

LED Indicator Lights Instruction

After logger connected to the device, check the status of NET light, COM light, READY light and whether there are data on the platform.

(There is only one light for each NET, COM and READY light.)

The normal operation status after the stick logger powered on:

- 1、 Successful connection to the server: NET light keeps on.
- 2、 Logger runs normally: READY light flashes.
- 3、 Successful connection to the inverter: COM light keeps on.

Light	Implication	Instruction
	Communicate with base station	1.Light off: Connection to the router failed. 2.On 1s/Off 1s (Slow flash) : Connection to the router succeeded. 3.Light on: Connection to the server succeeded. 4.On 100ms/Off 100ms (Fast flash) :Fast networking.
	Communicate with inverter	1.Light on: Logger connected to the inverter. 2.Light off: Connection to the inverter failed. 3.On 1s/Off 1s (Slow flash) : Logger communicating with inverter.
	Logger Running Status	1.Light off: Logger runs abnormally. 2.On 1s/Off 1s (Slow flash) : Logger runs normally. 3.On 100ms/Off 100ms (Fast flash) :Restore factory settings.

Abnormal Status Processing

If the data on platform is abnormal when the stick logger is running, please check the table below and complete a simple troubleshooting according to the status of indicator lights. If it still can not be resolved or indicator lights status do not show in the table below, please contact our Customer Service. (Note: Please using the following table query after power-on for 2mins.)

NET	COM	READY	Fault Description	Fault Cause	Solution
					
Any status	OFF	Any status	Communication with inverter abnormal	<ol style="list-style-type: none"> 1.Connection between stick logger and inverter loosen. 2.Inverter does not match with stick logger's communication rate. 	<ol style="list-style-type: none"> 1.Check the connection between stick logger and inverter. Remove the stick logger and install again. 2.Check inverter's communication rate to see if it matches with stick logger's.

Flash	ON	Flash	Communicate with router abnormal	<ol style="list-style-type: none"> 1.Stick logger does not have a network. 2.Antenna abnormal 3.Router WiFi signal strength weak. 	<ol style="list-style-type: none"> 1. Check if the wireless network configured. 2. Check the antenna, if there is any damage or loose. 3. Enhance Router WiFi signal strength.
OFF	OFF	OFF	Power supply abnormal	<ol style="list-style-type: none"> 1.Connection between stick logger and inverter loosen or abnormal. 2.Inverter power insufficient. 3.Stick Logger abnormal. 	<ol style="list-style-type: none"> 1.Check the connection, remove the stick logger and install again. 2.Check inverter output power. 3.Contact Customer Service.